

MDC200-048051 110VAC Input Brushless Controller

User's Guide



ANAHEIM AUTOMATION

4985 E. Landon Drive Anaheim, CA 92807
e-mail: info@anaheimautomation.com

(714) 992-6990 fax: (714) 992-0471
website: www.anaheimautomation.com

MDC200-048051 Driver Features

- Maximum Current Limit Setting from 1 - 5Amps (peak) up to 100W Power Output
- Internal or External Potentiometer Speed Control
- 48VDC Motor Voltage Bus
- 2-Quadrant Operation
- Hall Sensor Feedback
- Constant Velocity Mode
- Short Circuit Protection
- Requires 85 - 135 VAC Power Input
- Speed Out
- Fault Out
- Brake, Disable and Direction Inputs
- Selectable Ramp Up/Down
- Optically Isolated Inputs and Outputs
- Compact Size (6.25" x 4.35" x 1.93")
- Dual Mounting Option
- Detachable, Screw type Terminal Blocks

General Description

The MDC200-048051 driver is a velocity control driver designed to drive DC Brushless Motors from a supply of 120VAC. With a motor bus voltage of 48V, maximum phase current of 5A (peak) and power output of 100W, this driver eliminates the need for an external power supply. Using hall sensor feedback, a constant velocity mode can be selected. The driver is protected against over current (cycle-by-cycle or latched), hall sensor error and under voltage. When an error occurs, a fault light notifies the user. If the fault latch is enabled and an error occurs, the fault output goes low to notify the user. Included on the driver is an internal potentiometer to control the maximum phase current allowed into the motor and an internal potentiometer to control the speed of the motor. An optional external potentiometer (10K) can be used to control the speed as well. The direction of the motor can be preset by the direction control input. Other inputs to the drive include a run/stop and a motor freewheel input. When using the run/stop input, there are three ramp up/down profiles from standstill to select from. The run/stop input overrides all other inputs into the driver.

Pin Descriptions

The inputs on the MDC200-048051 are optically isolated with an anode (+) and cathode (-) both brought out to the user. With no current going through the Direction, Freewheel, and Run/Stop opto-diodes, the input is considered high. To enable the motor to Run, current must go through the Run/Stop input opto-diode. To Freewheel (remove energy from the motor) the motor, current must go through the Freewheel input opto-diode. To enable the input a minimum of 1.0 mA needs to be sourced or sunked through the opto-diode. This is done simply by placing a voltage of +5 to +7 VDC across two inputs of the opto-diode. If sourcing current into the inputs, then all three cathodes (-) should be tied together and grounded. If sinking current, then all three anodes (+) should be tied together to the +voltage. The PG Out and Fault output on the MDC200-048051 are an opto-decoupled open collector output. When normal operation occurs, this output will conduct current into the emitter. Care must be taken not to pass more than 50mA through this transistor.

Optically Isolated Inputs and Output

The following inputs and output to the MDC200-048051 are Optically Isolated.

Item	Pin #
PG Out	1 & 2
Direction	3 & 4
Freewheel	5 & 6
Run Stop	7 & 8
Fault Out	9 & 10

To enable an input, apply a DC voltage source of +5VDC to +7VDC across the inputs. The Anodes (+) are pins 3, 5, and 7 and the Cathodes (-) are pins 4, 6, and 8.

Absolute Maximum Ratings

Output Current Rating:

Adjustable 1.0 - 5.0 amperes per phase maximum operating peak current.

(0.5 - 2.5 amperes per phase maximum operating continuous current)

Power Requirements: (TB4, Pins 1 and 2)

85VAC (min) - 135VAC (max)

Operating Temperature:

Heat Sink: 0° - 70° C

Hall Sensor Power Output:

6.25V @ 30mA maximum. Typical current draw from hall sensors is 20mA.

All three Hall Sensor inputs are pulled up through 20K ohm resistors.

The external speed control potentiometer must be 10K ohms.

Open Loop/Closed Loop (Constant Velocity Mode)

The driver can either be set for Open Loop or Closed Loop operation. Open Loop operation is used for applications where the speed of the motor needs to change according to the load. Closed Loop operation is used for applications where speed regulation is needed. Under closed loop operation, the speed is regulated despite changes to the load and the power supply voltage.

To operate Open Loop, the O/C LOOP switch (SW1 - pos1) must be in the 'on' position.

To operate Closed Loop, the O/C LOOP switch must be in the 'off' position and the CLADJ potentiometer (R3) and CLADJ dip switches (SW1 - pos2-4) must be set to optimize the driver for each application. The Closed Loop adjustments are needed for faster and slower motor operation, within the restrictions of the motor rated speed. The adjustments provide a direct duty cycle to the driver with respect to the required motor speed.

The following tables show Closed Loop potentiometer and dip switch settings for each motor. These adjustments will set the maximum setting of the internal/external speed potentiometer to the motors maximum running speed. If operation at slower speeds is needed for the application, CL POT can be adjusted toward 100% until desired motor speed is achieved. The motor speed can be monitored by measuring the pulse rate of PG OUT (TB2 - pin 1 & 2)

4-Pole Motors

Motor	CL1	CL2	CL3	CL POT	MAX SPD (RPM)	MIN SPD (RPM)
BLWR110S-15V-8000	On	On	On	80%	8000	500
BLWR111S-24V-10000	On	On	On	50%	10050	825
BLWR112S-24V-3700	On	Off	On	100%	3735	450
BLWR231D-36V-4000	On	Off	On	65%	4010	550
BLWR232D-36V-4000	On	Off	On	65%	4010	550
BLWR233D-36V-4000	On	Off	On	65%	4010	550
BLWR234D-36V-4000	On	Off	On	65%	4010	550
BLWR235D-36V-4000	On	Off	On	65%	4010	550
BLWR232S-24V-1350	Off	Off	Off	0%	1600	200
BLWS231D-36V-4000 BLWS231S-36V-4000	On	Off	On	65%	4010	550
BLWS232D-36V-4000 BLWS232S-36V-4000	On	Off	On	65%	4010	550
BLWS233S-36V-4000	On	Off	On	65%	4010	550
BLWS234D-36V-4000 BLWS234S-36V-4000	On	Off	On	65%	4010	550
BLWS235-36V-4000	On	Off	On	65%	4010	550

8-Pole Motors

Motor	CL1	CL2	CL3	CL POT	MAX SPD (RPM)	MIN SPD (RPM)
BLY171S-17V-8000	On	On	On	0%	7500	500
BLY172S-17V-9500	On	On	On	0%	9000	500
BLY171S-24V-4000	On	On	On	80%	4000	250
BLY172D-24V-4000 BLY172S-24V-4000	On	On	On	80%	4000	250
BLY173D-24V-4000	On	On	On	80%	4000	250
BLY174D-24V-4000 BLY174S-24V-4000	On	On	On	80%	4000	250
BLY341D-48V-3200 BLY341S-48V-3200	Off	On	On	40%	3200	250
BLY342D-24V-3000	Off	On	On	40%	3000	250
BLY342D-30V-3000 BLY342D-30V-3000	Off	On	On	40%	3000	250
BLY342D-48V-3200 BLY342S-48V-3200	Off	On	On	30%	3200	250
BLY343D-48V-3200 BLY343S-48V-3200	Off	On	On	30%	3200	250
BLY343S-30V-3000	Off	On	On	40%	3000	250
BLY344D-48V-3200 BLY344S-48V-3200	Off	On	On	30%	3200	250
BLZ362S-36V-3500	Off	On	On	10%	3500	330
BLZ362S-160V-3500	Off	On	On	10%	3500	330
BLZ482S-160V-3500	Off	On	On	10%	3500	330
BLZ242S-24V-3500	Off	On	On	10%	3500	330

Commutation Sequence

	Step					
	1	2	3	4	5	6
Phase A	+	Z	-	-	Z	+
Phase B	Z	+	+	Z	-	-
Phase C	-	-	Z	+	+	Z
Hall A	1	1	0	0	0	1
Hall B	0	1	1	1	0	0
Hall C	0	0	0	1	1	1

120° Hall Spacing Sequence Forward

	Step					
	1	2	3	4	5	6
Phase A	-	Z	+	+	Z	-
Phase B	Z	-	-	Z	+	+
Phase C	+	+	Z	-	-	Z
Hall A	1	1	0	0	0	1
Hall B	0	1	1	1	0	0
Hall C	0	0	0	1	1	1

120° Hall Spacing Sequence Reverse

	Step					
	1	2	3	4	5	6
Phase A	+	Z	-	-	Z	+
Phase B	Z	+	+	Z	-	-
Phase C	-	-	Z	+	+	Z
Hall A	1	1	1	0	0	0
Hall B	0	1	1	1	0	0
Hall C	0	0	1	1	1	0

60° Hall Spacing Sequence Forward

	Step					
	1	2	3	4	5	6
Phase A	-	Z	+	+	Z	-
Phase B	Z	-	-	Z	+	+
Phase C	+	+	Z	-	-	Z
Hall A	1	1	1	0	0	0
Hall B	0	1	1	1	0	0
Hall C	0	0	1	1	1	0

60° Hall Spacing Sequence Reverse

+ = Top Transistor ON, Bottom Transistor OFF, Current Flows into this wire

- = Top Transistor OFF, Bottom Transistor ON, Current Flows out of this wire

Z = Top Transistor OFF, Bottom Transistor OFF, No current into or out of this wire (High Impedance)

Motor Connection

Refer to the hookup diagram for typical driver applications. When connecting a motor for the first time, connect the hall sensor wires (5 of them) to the driver. **DO NOT CONNECT THE PHASES YET.** Turn on power and rotate the motor by hand. If the RED FAULT LED comes on, the hall phases are incorrectly wired. If the RED FAULT LED does not come on then the hall wires are connected correctly. Power the unit down and proceed to connect the motor phases. If the motor does not run or runs erratically, power down and check the speed potentiometer and make sure the phases are connected correctly. There are six different ways to connect the phase wires, and normally only two will allow the motor to rotate, but only one is correct. If the direction of the motor is changed and the no-load current of the motor is approximately the same and the motor runs smoothly in both directions then the phase wires are correct.

The wiring of the motor phases should be separated from the hall and input connections to not allow a possible source of interference.

Terminal and Dip Switch Descriptions

Pin #	Description
1	Hall Sensor Power
2	Hall Sensor A
3	Hall Sensor B
4	Hall Sensor C
5	Hall Sensor Ground

TB1: Motor Hall Terminals

Pin #	Description
1	Phase A
2	Phase B
3	Phase C

TB4: Motor Phase Terminals

SW #	Description
1	O/C LOOP
2	CL1
3	CL2
4	CL3

SW1: Dip Switch

Pin #	Description
1	PG OUT (collector)
2	PG OUT (emitter)
3	Direction (+)
4	Direction (-)
5	Freewheel (+)
6	Freewheel (-)
7	Run/Stop (+)
8	Run/Stop (-)
9	Fault Out (collector)
10	Fault Out (emitter)

TB2: Opto-isolated Control Inputs and Outputs

SW #	Description
1	INT/EXT SPEED
2	FLT LATCH
3	RAMP 1
4	RAMP 2
5	60/120

SW2: Dip Switch

Pin #	Description
1	AC Hot
2	AC Neutral
3	EARTH GND (must be connected)

TB3: AC Voltage In Terminals

TB#	Pin #	Description
1	1	Pot (+) Top
3	6	Pot Wiper
3	7	Pot (-) Bottom

P1: 10K External Pot

Dip Switch Settings

Function	SW1	SW2	SW3	SW4	SW5
Internal Speed Control (R46)	Off	---	---	---	---
External Speed Control (TB3 - Pin 6)	On	---	---	---	---
Over Current Latching	---	On	---	---	---
Over Current Cycle-by-Cycle	---	Off	---	---	---
Ramp Profile 1 (4 Sec)	---	---	Off	Off	---
Ramp Profile 2 (2 Sec)	---	---	Off	On	---
Ramp Profile 3 (1 Sec)	---	---	On	Off	---
Ramp Profile 4 (500mSec)	---	---	On	On	---
60° Hall Sensor Spacing	---	---	---	---	Off
120° Hall Sensor Spacing	---	---	---	---	On
Standard Product (Ready to Ship)	Off	Off	Off	Off	On

SW1: Speed Adjustment, Over Current, and Ramp settings

Dip Switch Settings (cont.)

Function	SW1	SW2	SW3	SW4	SW5
Constant Speed Mode (Closed Loop)	Off	---	---	---	---
Voltage Controlled Speed Mode (Open Loop)	On	---	---	---	---
Closed Loop Compensation 1	---	---	---	---	---
Closed Loop Compensation 2	---	---	---	---	---
Closed Loop Compensation 3	---	---	---	---	---
Standard Product (Ready to Ship)	On	Off	Off	Off	Off

SW1: Open Loop and Closed Loop. If Closed Loop selected, Closed Loop compensation switches must be set according to the motor speed desired.

Motor Freewheel

The motor freewheel feature allows the de-energizing of the motor phases. Zero current into this input causes the motor to run at the given speed, while ~1mA into this input causes the motor to coast to a stop.

Motor Run/Stop

The motor run/stop feature allows the stopping of a motor by shorting out the bottom drives of the three phases. A low at this input allows the motor to run, while a high (open) input does not allow motor operation and if operating causes rapid deceleration.

Motor Direction

The motor direction feature allows the changing of the rotation of the motor. This input should not be changed while motion is in progress. Zero current into this input causes the motor to turn in the CW direction, while ~1mA into this input causes the motor to turn in the CCW direction.

Speed Adjust Setting

There are two ways to set the speed on this drive. One is to use the onboard or external potentiometer. To use the onboard potentiometer, set INT/EXT SPD Switch to the off position (default). To use the external 10K potentiometer, set INT/EXT SPD switch to the on position. If an external potentiometer is used to control the speed of the motor, connect the pot wiper to P1 - pin 'W', the positive end of the potentiometer to P1 - pin 'H' and the negative end to P1 - pin 'L'.

Fault Protection and Fault Output

Over current protection can be provided by means of an over current latch function by setting the 'FLT LATCH' dip switch. If a motor current level exceeding the current limit set by the internal or external current limit potentiometer is produced, an over current latch is activated, shutting off the output and turning the fault output low (logic "0"). This driver is equipped with a FAULT LED to alert the user of the following conditions.

1. Invalid Sensor Input Code
2. Over Current. The driver is equipped with cycle-by-cycle current limiting or over current latch.
3. Under-voltage Lockout activation at 9.1VDC for the input voltage and 4.5VDC for Hall Sensor voltage.

The fault output on the MDC200-048051 is an opto-decoupled open collector output. When a latched fault condition occurs, no current conducts into the emitter. When normal operation occurs, this output will conduct current into the emitter. Care must be taken not to pass more than 50mA through this transistor.

Speed Output

The PG OUT terminal (TB2 - pin 1 and 2) is used to determine the speed of the motor shaft. An opto-decoupled open collector output is shown at a rate of 4 pulses for 1 revolution of an 8-pole motor, 3 pulses for 1 revolution of a 6-pole motor, and 2 pulses for 1 revolution of a 4-pole motor. Care must be taken not to pass more than 50mA through this transistor.

# Poles	RPM
8	15 * PG OUT (in Hz)
6	20 * PG OUT (in Hz)
4	30 * PG OUT (in Hz)

Heating Considerations

The temperature of the heat sink should never be allowed to rise above 70° Celsius. If necessary, mount the unit to an additional heat sink or air should be blown across the heat sink to maintain suitable temperatures.

Dimensions

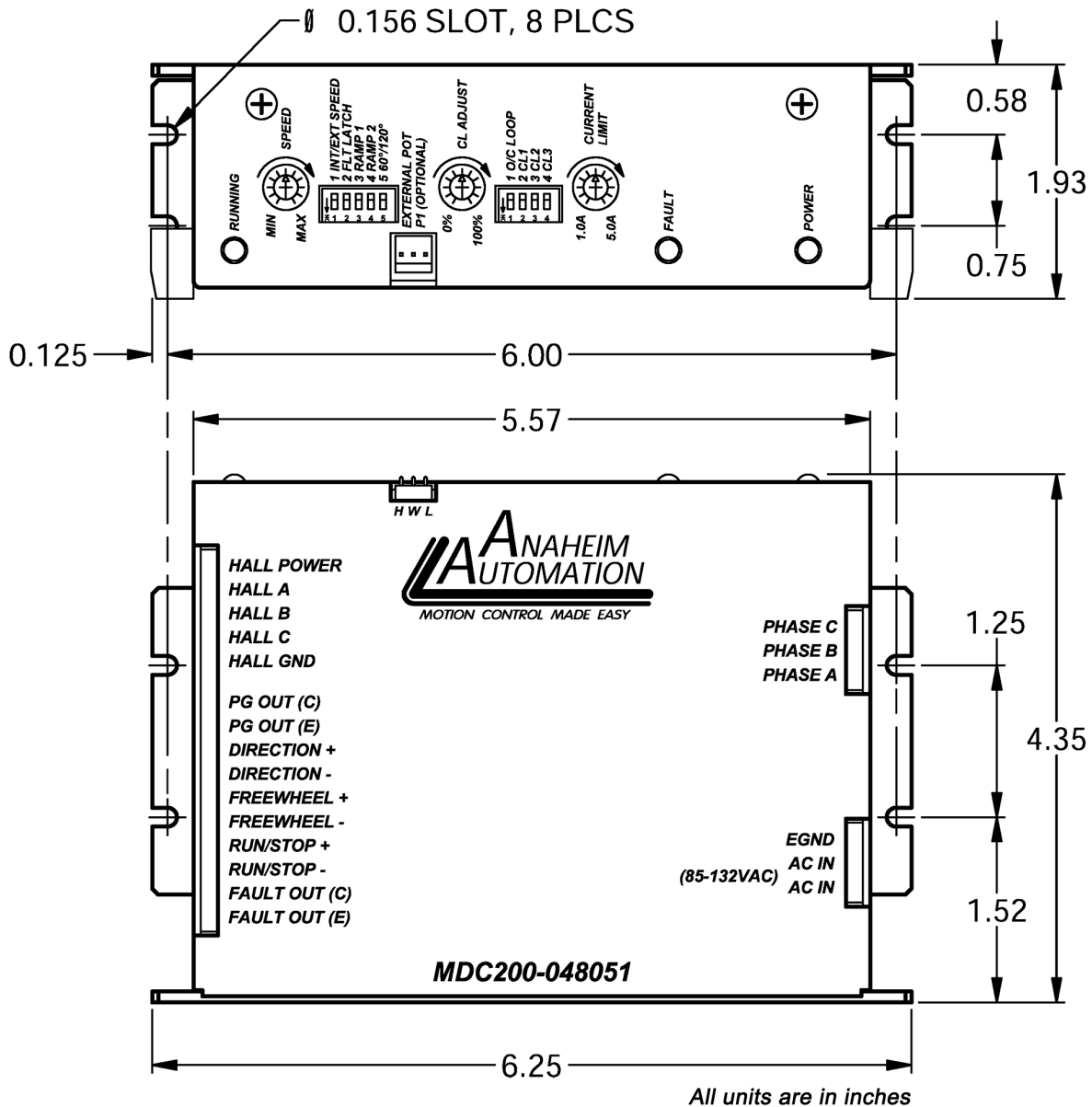

Typical Wiring Diagram

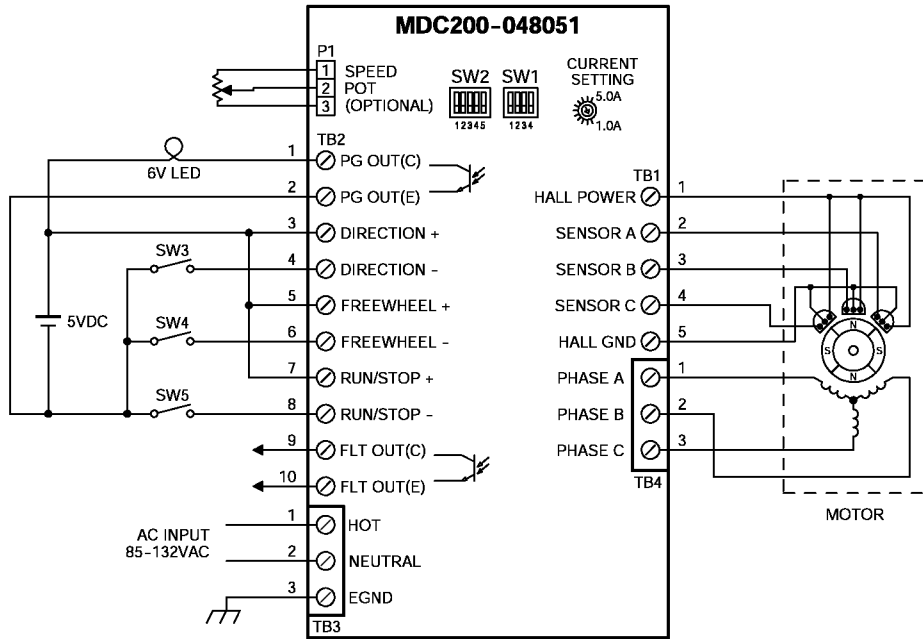

COPYRIGHT

Copyright 2012 by Anaheim Automation. All rights reserved. No part of this publication may be reproduced, transmitted, transcribed, stored in a retrieval system, or translated into any language, in any form or by any means, electronic, mechanical, magnetic, optical, chemical, manual, or otherwise, without the prior written permission of Anaheim Automation, 4985 E Landon Drive, Anaheim, CA 92807.

DISCLAIMER

Though every effort has been made to supply complete and accurate information in this manual, the contents are subject to change without notice or obligation to inform the buyer. **In no event will Anaheim Automation be liable for direct, indirect, special, incidental, or consequential damages arising out of the use or inability to use the product or documentation.**

Anaheim Automation's general policy does not recommend the use of its' products in life support applications wherein a failure or malfunction of the product may directly threaten life or injury. Per Anaheim Automation's Terms and Conditions, the user of Anaheim Automation products in life support applications assumes all risks of such use and indemnifies Anaheim Automation against all damages.

LIMITED WARRANTY

All Anaheim Automation products are warranted against defects in workmanship, materials and construction, when used under Normal Operating Conditions and when used in accordance with specifications. This warranty shall be in effect for a period of twelve months from the date of purchase or eighteen months from the date of manufacture, whichever comes first. **Warranty provisions may be voided if products are subjected to physical modifications, damage, abuse, or misuse.**

Anaheim Automation will repair or replace at its' option, any product which has been found to be defective and is within the warranty period, provided that the item is shipped freight prepaid, with previous authorization (RMA#) to Anaheim Automation's plant in Anaheim, California.

TECHNICAL SUPPORT

If you should require technical support or if you have problems using any of the equipment covered by this manual, please read the manual completely to see if it will answer the questions you have. If you need assistance beyond what this manual can provide, contact your Local Distributor where you purchased the unit, or contact the factory direct.

ANAHEIM AUTOMATION